



Institut
Mines-Telecom

Baseband Filtering

Chadi Jabbour



Objectives:

- ▶ Evaluate the complexity of a filter from its specifications
- ▶ Study the physical implementation of the filters

Outline:

- ▶ Introduction
- ▶ Filter specifications
 - ▶ Transfer Functions
 - ▶ Filter Constraints
- ▶ Filter synthesis using Standard approximations
 - ▶ Prototype Filter
 - ▶ Frequency transformations
- ▶ Filter implementations

Introduction

Filter specifications

Standards Approximations

Filter Implementation

Why do we need Filtering?

Radio channel selection : heterodyne architecture

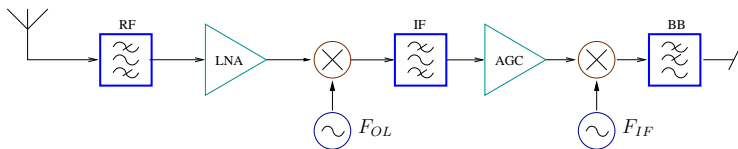

- ▶ The filtering is distributed in the reception chain (RF, IF, BB).
- ▶ The technology used for these different filters is closely related to the frequency of the signal to be processed.

Why do we need Filtering?

$$x_d(t) = x(t) \cdot T_s \sum_{k \in \mathbb{Z}} \delta(t - k T_s) \Rightarrow X_d(f) = \sum_{k \in \mathbb{Z}} X(f - k F_s)$$

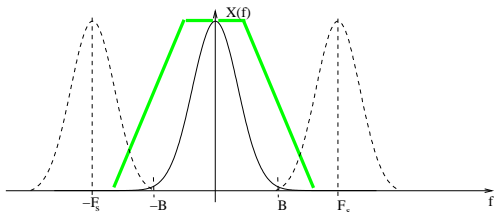

Anti alias Filtering

In order to sample at a frequency $F_s = 2B$ (Nyquist-Shannon), we must guarantee that the signal spectrum does not have components higher at frequencies highest than B . This is the job of the anti-alias Filter (AAF)

Introduction

Filter specifications

Standards Approximations

Filter Implementation

Lumped elements filter

- ▶ When the device dimension d is in the same order of magnitude of the wavelength λ , the wave propagation in the device should be analyzed
- ▶ Example: surface Acoustic Wave (SAW) filter with $v = 4000\text{m/s}$, $f = 2\text{ GHz} \implies \lambda = 2\text{ }\mu\text{m}$. In this case, the propagation should be studied.
- ▶ When d is much lower than λ ($d < \lambda/10$), we may neglect the propagation phenomena. This is the lumped element model of the circuit where circuit elements (R, L, C) are considered like points and described by Kirchhoff laws



Transfer function

A linear filter is described by its impulse response $h(t)$. The Laplace transform $T(p)$ (also noted $T(s)$) of $h(t)$, $T(p) = \frac{Y(p)}{X(p)}$ is the transfer function of the filter

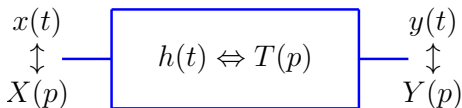

$$\underbrace{\sum_j i_{kj} = 0}_{\text{Kirchhoff law}} \quad \text{and} \quad \underbrace{i = C \frac{dv}{dt} \xleftrightarrow{\mathcal{L}} I(p) = C p V(p)}_{\text{Behavioral equations}}$$

$$T(p) = \frac{\prod_{j=1}^m (p - z_j)}{\prod_{i=1}^n (p - p_i)}$$

p_i : poles

z_j : zeros

n : filter order

Harmonic and transient response

For a sine input with a pulsation ω :

$$x(t) = e^{j\omega t} \cdot \mathbf{1}_{\{t>0\}} \Leftrightarrow \mathcal{L}\{x(t)\} = X(p) = \frac{1}{p-j\omega}$$

$$Y(p) = T(p) \cdot X(p) = \frac{N(p)}{\prod_{i=1}^n (p-p_i)} \cdot \frac{1}{p-j\omega} = \sum_{i=1}^n \frac{C_i}{p-p_i} + \frac{C_{n+1}}{p-j\omega}$$

$$C_{n+1} = [T(p)]_{p=j\omega} = T(j\omega)$$

$$y(t) = \underbrace{\sum_{i=1}^n C_i e^{p_i t}}_{\text{Transient response}} + \underbrace{T(j\omega) e^{j\omega t}}_{\text{Harmonic response}}$$

- ▶ Stability: A system is stable if its output is bounded for a bounded input or in other terms, if its transient response is evanescent
 - ▶ If the denominator order is higher or equal to the numerator order $m \leq n$. (Often true in practice)
 - ▶ All the poles have a negative real part in the Laplace domain $\text{Re}(p_j) < 0$

- ▶ Causality: In a causal system, the output never precedes the input

Filter Attenuation and group delay

Attenuation is commonly expressed in dB

$$A(\omega) = -20 \log_{10} |T(j\omega)|$$

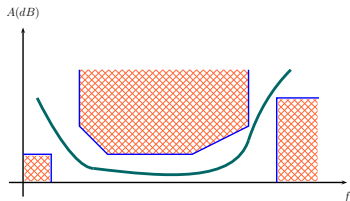

To study the delay behavior of a filter with respect to frequency, we use the group delay

$$t_g(\omega) = -\frac{\partial \arg[T(j\omega)]}{\partial \omega}$$

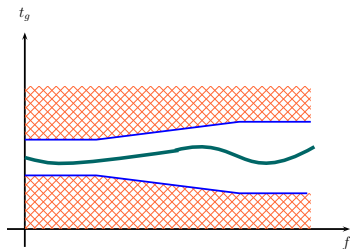

Exercise 1: RC filter

We have the following RC filter:

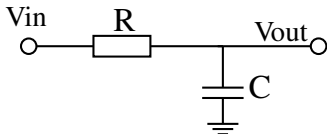

- ▶ Calculate the transfer function $T(p) = \frac{V_{out}(p)}{V_{in}(p)}$
- ▶ Is the filter stable?
- ▶ Determine the attenuation and the group delay expression.
- ▶ Trace them for an $R = 10 \text{ K}\Omega$ and $C = 1 \text{ nF}$.

Introduction

Filter specifications

Standards Approximations

Filter Implementation

- ▶ The standard approximation approach is based on the construction of a normalized low-pass filter in amplitude and frequency by a characteristic function Ψ_n .
- ▶ This normalized low-pass filter is called prototype filter
- ▶ The normalized complex variable corresponding to the prototype is $S = \Sigma + j \Omega$:

$$A(\Omega) = 10 \log_{10}[1 + \epsilon^2 \Psi_n^2(\Omega)] \quad , \quad |T(\Omega)|^2 = \frac{1}{1 + \epsilon^2 \Psi_n^2(\Omega)}$$

- ▶ The approximation of the prototype is to determine the characteristic function Ψ_n which satisfies the magnitude constraint.

Prototype Definition

The prototype is a normalized low pass filter

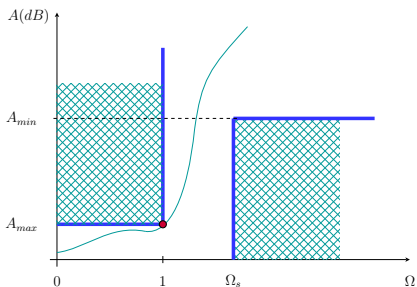

- ▶ Its pass band is 1
- ▶ A_{max} is maximum allowed attenuation inside the useful bandwidth
- ▶ A_{min} is the minimum allowed attenuation at the normalized pulsation Ω_s

Order calculation

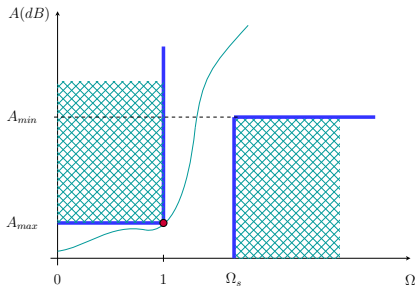

$$A(\Omega) = 10 \log_{10}[1 + \epsilon^2 \Psi_n^2(\Omega)]$$

$$\Omega \in [0, 1] \Rightarrow |\Psi_n(\Omega)| \leq 1$$

$$\Psi_n(1) = 1$$

$$A_{max} = 10 \log_{10}(1 + \epsilon^2)$$

The following expression allows to determine the filter order for a given Ψ :

$$A_s = 10 \log_{10}[1 + \epsilon^2 \Psi_n^2(\Omega_s)] \geq A_{min} \quad \Psi_n(\Omega_s) \geq D = \sqrt{\frac{10^{A_{min}/10} - 1}{10^{A_{max}/10} - 1}}$$

There are two main classes of approximations:

▶ Polynomial Approximations

▶ Butterworth Approximation: $\Psi_n(\Omega) = \Omega^n$

▶ Tchebycheff Approximation: $\Psi_n(\Omega) = T_n(\Omega)$
 T_n : Tchebycheff polynome of order n

▶ Rationnal Approximations

▶ Tchebycheff in attenuated band: $\Psi_n(\Omega) = \frac{T_n(\Omega_s)}{T_n(\frac{\Omega_s}{\Omega})}$

▶ Cauer Approximation or Elliptic:

n even	n odd
$\Psi_n(\Omega) = C_1 \prod_{i=1}^{n/2} \frac{\Omega^2 - \Omega_{oi}^2}{\Omega^2 - \Omega_{zi}^2}$	$\Psi_n(\Omega) = C_2 \Omega \prod_{i=1}^{n-1/2} \frac{\Omega^2 - \Omega_{oi}^2}{\Omega^2 - \Omega_{zi}^2}$
$\Omega_{oi} \cdot \Omega_{zi} = \Omega_s$	

Approximation Comparison

Examples of standard approximation ($n=5$, $A_{\max}=3$ dB)

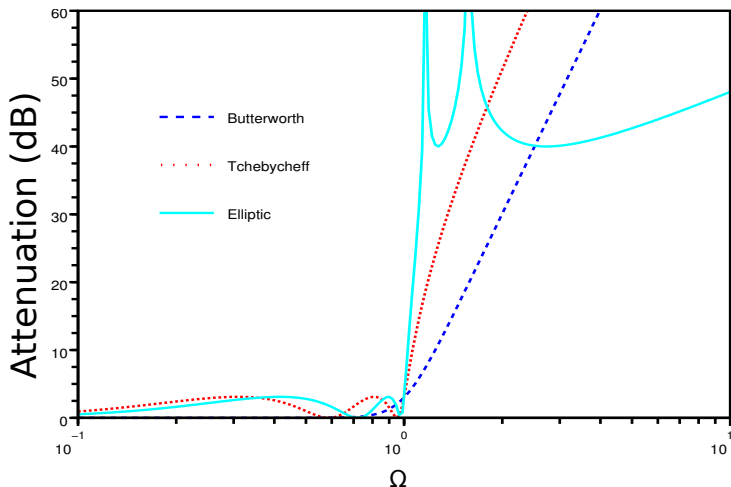

How to choose the approximation

The choice of an approximation over another depends on several parameters:

- ▶ The order: the implementation complexity and power consumption are approximately proportional to the order
- ▶ The in-band ripple: the attenuation variation in the useful bandwidth. The prototype calculation just guarantees that its maximum value is lower than A_{max}
- ▶ The out-of-band ripple: the attenuation variation in the stop bandwidth. The prototype calculation just guarantees that its minimum value is lower than A_{min}
- ▶ Implementation constraints: step-response, robustness to component variations ...

Frequency transformation

main transformations $S = f(p)$ of prototype:

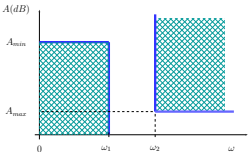
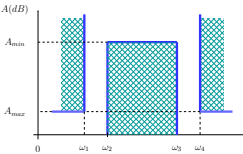
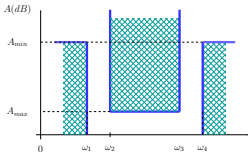
<p>(1) High-pass:</p> 	<p>(2) Stop-band:</p> 	<p>(3) Pass-band:</p> 
$S = \frac{\omega_2}{p}$ $\Omega_s = \frac{\omega_2}{\omega_1}$	$S = \frac{B_{rad}}{\omega_o} \left[\frac{p}{\omega_o} + \frac{\omega_o}{p} \right]^{-1}$ $B_{rad} = \omega_4 - \omega_1$ $\Omega_s = \frac{\omega_4 - \omega_1}{\omega_3 - \omega_2}$ <p>Condition: $\omega_1 \cdot \omega_4 = \omega_2 \cdot \omega_3 = \omega_o^2$</p>	$S = \frac{\omega_o}{B_{rad}} \left[\frac{p}{\omega_o} + \frac{\omega_o}{p} \right]$ $B_{rad} = \omega_3 - \omega_2$

Filter construction methodology with standard approx.

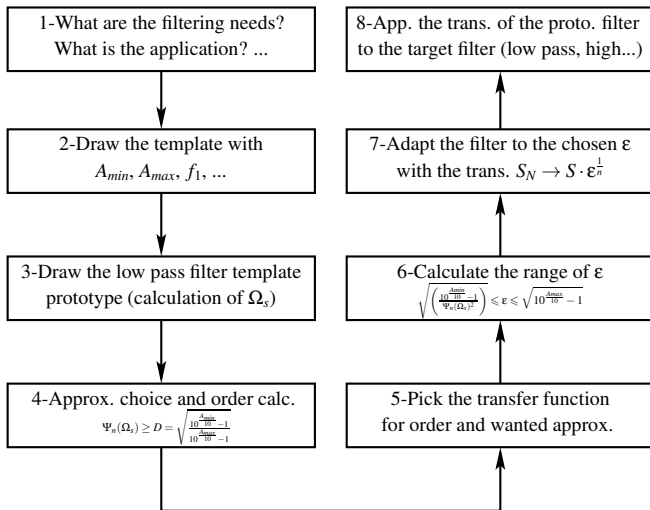

Step 1: What are the needs

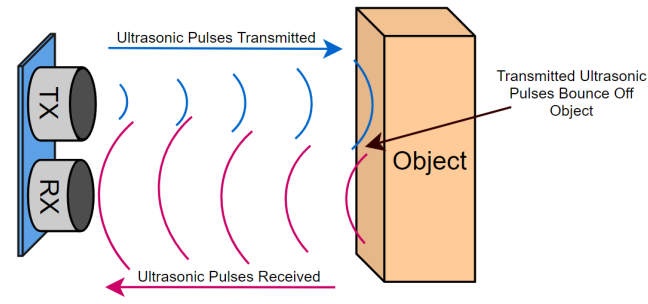

Scenario: Mickael wants to use an ultrasonic sensor to measure distance but has accuracy issues. Mikael calls her friend Jackson for help. After analyzing the problem, he concludes that the measurement uncertainties are due to the audible frequencies ($f < 20$ kHz).

Steps 2 and 3: high pass filter and prototype filter Templates

Step 2: To attenuate these frequencies, we decide to use a high pass filter. To determine the specifications of this filter, Mikael and Jackson look at the various parameters of the application and conclude that they can afford a maximum attenuation of less than 2 dB in the useful band ($f > 50$ kHz). Furthermore, in the attenuated band ($f < 20$ kHz), the minimum attenuation required must be 10 dB.

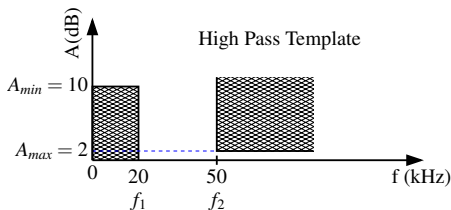

Step 2: High pass filter template

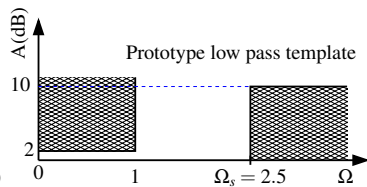

Step 3: Prototype low pass filter template

Step 4: Approx choice and order calculation

Step 4: We decide to use a Butterworth approximation characterized by $\Psi_n(\Omega) = \Omega^n$.

To determine the order, we simply solve the following equation:

$$\Psi_n(\Omega_s) \geq D = \sqrt{\frac{10^{A_{min}/10} - 1}{10^{A_{max}/10} - 1}}$$

$$\Omega_s^n \geq \sqrt{\frac{10^{A_{min}/10} - 1}{10^{A_{max}/10} - 1}}$$

For $A_{min} = 10$ dB $A_{max} = 2$ dB, and $\Omega_s = 2.5$

$$D = \sqrt{\frac{10^1 - 1}{10^{0.2} - 1}} = 3.92 \longrightarrow n > \frac{\log(D)}{\log(\Omega_s)} = 1.49$$

The order is 1.49 but since the order must be integer $\longrightarrow n = 2$

Filter construction methodology with standard approx.

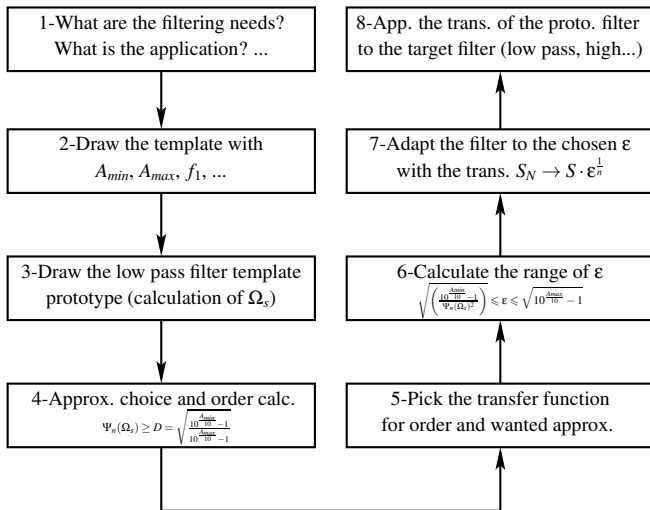

Step 5: Raise the transfer function

Step 5: We note the transfer function in the Butterworth table

$$H_{\text{Lowpass-NormInBand-Norm3dB}}(S_N) = \frac{1}{S_N^2 + \sqrt{2}S_N + 1}$$

Problem

This table is defined for an A_{max} of 3 dB or in other words for a normalized cutoff frequency equal to 1.

Order	Numerator	Denominator
1	1	$S_N + 1$
2	1	$S_N^2 + \sqrt{2}S_N + 1$
3	1	$(S_N + 1)(S_N^2 + S_N + 1)$

Butterworth table with $A_{\text{max}} = 3$ dB

Step 6: Calculate the range of ϵ

Solution

It is using ϵ that we can adjust the filter to our specific needs.

We know that $A(\Omega) = 10 \log_{10}(1 + \epsilon^2 \Psi_n^2(\Omega))$, by solving $A(\Omega = 1) < A_{max}$ and $A(\Omega = \Omega_s) > A_{min}$, we get

$$\sqrt{\left(\frac{10^{\frac{A_{min}}{10}} - 1}{\Psi_n^2(\Omega_s)}\right)} \leq \epsilon \leq \sqrt{10^{\frac{A_{max}}{10}} - 1}$$

For $A_{min} = 10$ dB, $A_{max} = 2$ dB, $\Omega_s = 2.5$, $n = 2$ and a Butterworth approximation

$$0.48 \leq \epsilon \leq 0.76$$

Step 7: Match the filter to ϵ

To adjust the filter to the chosen ϵ , $S_N \rightarrow S \cdot \epsilon^{\frac{1}{n}}$,

$$H_{\text{Lowpass-StandardInBand}}(S) = \frac{1}{\epsilon S^2 + \sqrt{2\epsilon}S + 1}$$

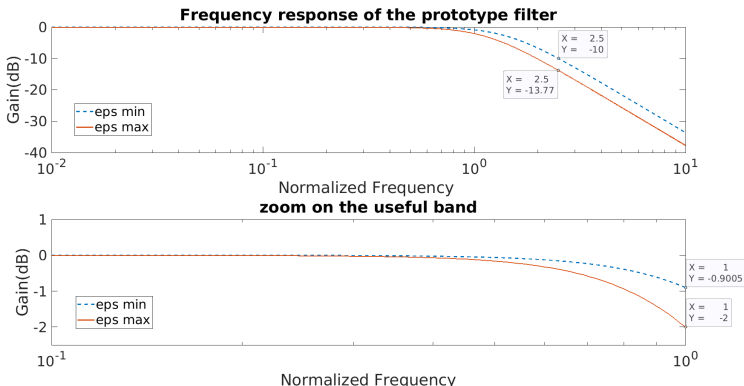

Freq. prototype low pass filter for ϵ_{max} and ϵ_{min}

Step 8: Find target filter

To construct the high pass filter: $S \rightarrow \frac{2\pi f_2}{p} = \frac{\omega_2}{p}$.

$$H_{Highpass}(p) = \frac{p^2}{p^2 + \sqrt{2}\epsilon\omega_2 p + \epsilon\omega_2^2}$$

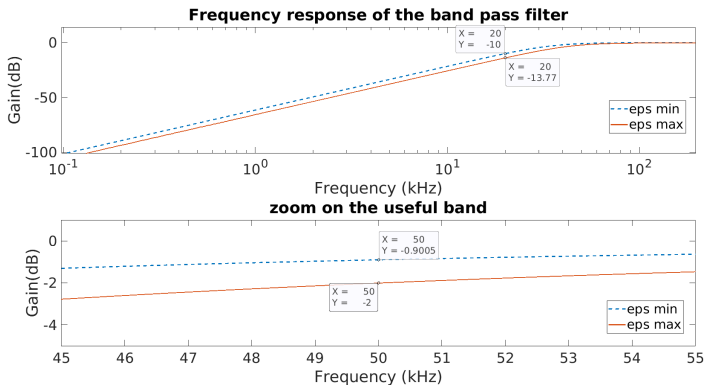

Freq. response of the high pass filter for ϵ_{max} and ϵ_{min}

Comparison between the two filters

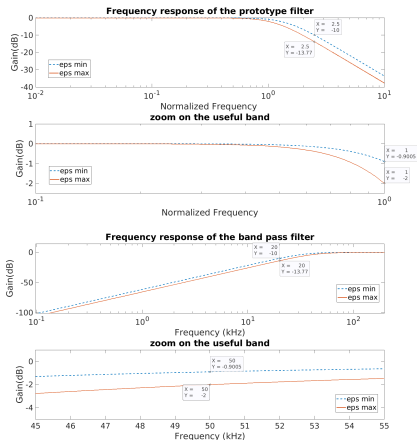

The HP attenuations at $f_1=20$ kHz and $f_2 = 50$ kHz are resp. equal to $\Omega=1$ and $\Omega = \Omega_s = 2.5$ for the LP Prototype

Exercise 2: USB communication filter

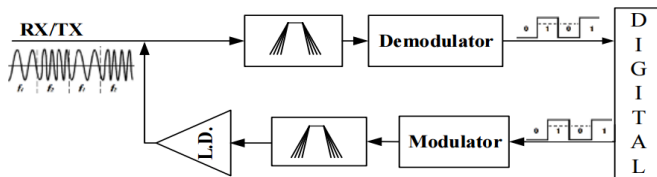

1. Determine the bandpass filter template with a geometric symmetry.
2. Determine the selectivity parameter Ω_S and the low-pass prototype template.
3. Calculate the order of the prototype filter for a polynomial approximation of Butterworth.
4. Calculate the possible range for ϵ
5. Using the Butterworth table, determine the transfer function of the prototype filter in the Laplace domain for ϵ_{min} .
6. Determine the expression of the equivalent bandpass selection filter.

Introduction

Filter specifications

Standards Approximations

Filter Implementation

The choice of a particular technology is guided by a large number of criteria

- ▶ Noise
- ▶ Linearity
- ▶ Central frequency and bandwidth
- ▶ Complexity and power consumption
- ▶ Robustness to component variations, temperature variations, voltage variations ...
- ▶ Ease of calibration
- ▶ ...

LC Filters

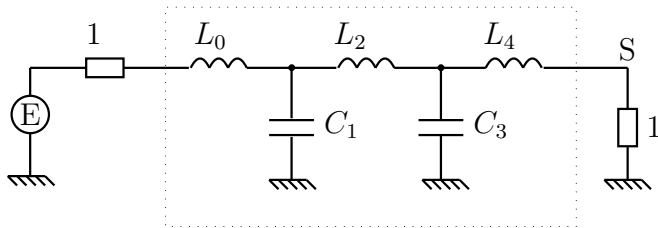

Prototype of a 5th order LC filter

k odd	k even
$C_k = 2 \sin \left[\frac{(2k+1)\pi}{2n} \right]$	$L_k = 2 \sin \left[\frac{(2k+1)\pi}{2n} \right]$

Value of components L and C (Butterworth, $A_{max} = 3$ dB)

Advantages:

- ▶ Passive: thus no internal power consumption
- ▶ Highly linear
- ▶ Noiseless (in Theory)

Drawbacks:

- ▶ Inductors are very bulky and sensitive (High area, long design time)
- ▶ Component variation: a calibration is often needed to adjust the frequency response of the filter
- ▶ Inductors in practice have a resistance in series due to interconnections. This limits the rejection and adds noise.

Active RC filters

Active RC filters are constructed using resistors, capacitors and amplifiers.

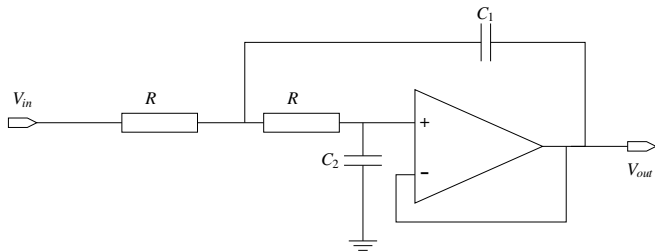

Sallen-Key cell:

$$T(p) = \frac{\omega_o^2}{p^2 + \frac{\omega_o}{Q_o} p + \omega_o^2} , \quad \omega_o = \frac{1}{R\sqrt{C_1 C_2}} , \quad Q_o = \frac{1}{2} \sqrt{\frac{C_1}{C_2}}$$

Advantages:

- ▶ Good integration
- ▶ Good linearity because it is a closed loop system
- ▶ Can be easily adapted to implement any kind of filter (low pass, high pass ...)

Drawbacks:

- ▶ The filter performance (noise, out-of-rejection ...) depends highly on the amplifier performance (DC Gain, Gain bandwidth product, slew rate..). The better the wanted performance, the higher the needed power consumption.
- ▶ Component variation: a calibration is often needed to adjust the frequency response of the filter

Active Gm-C filters

Active GmC filters are constructed using transconductance and capacitors.

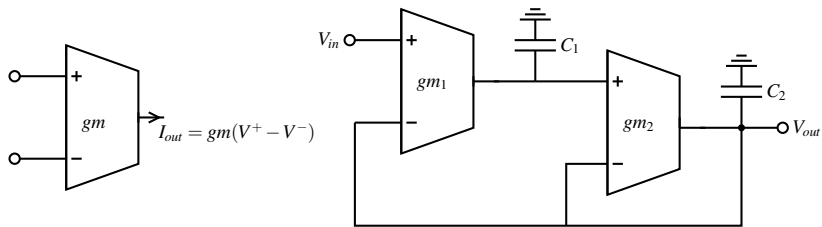

2nd order Gm-C cell:

$$T(p) = \frac{\frac{gm_1 gm_2}{C_1 C_2}}{p^2 + \frac{gm_2}{C_2} p + \frac{gm_1 gm_2}{C_1 C_2}}$$

Advantages:

- ▶ Very good integration in an integrated circuit
- ▶ Low power consumption compared with RC filters
- ▶ Can be easily adapted to implement any kind of filter (low pass, high pass ...)

Drawbacks:

- ▶ The linearity is limited because the signal swing at the transconductance inputs is high
- ▶ Component variation: a calibration is often needed to adjust the frequency response of the filter

Switched capacitor circuits

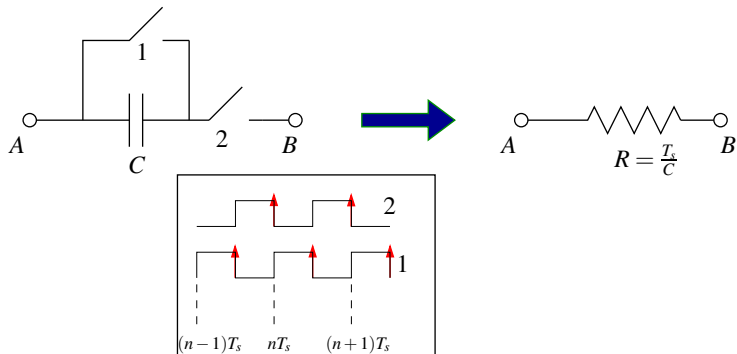

Switched capacitor resistors

This switched capacitor systems behaves like a resistance in average and can be used to replace resistors in RC circuits

Switched capacitor filter

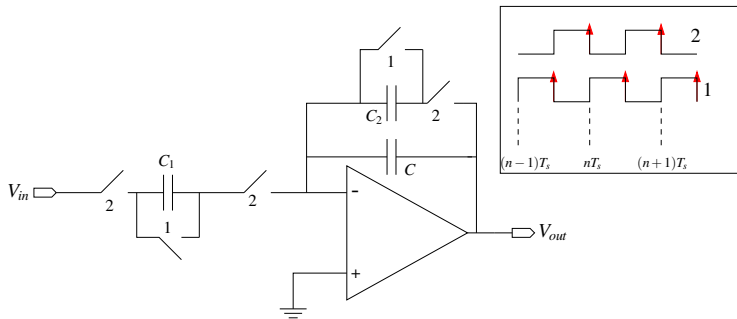

$$T(z) = \frac{V_{out}(z)}{V_{in}(z)} = -\frac{C_1}{C_2\left(1 + \frac{C}{C_2} - \frac{C}{C_2}z^{-1}\right)}$$

$$T(j\omega) = ?? \text{ for } f \ll f_s$$

Discrete time filters: Bilinear Transform

Transform from Laplace domain to the z domain:

$$p = f(z) = \frac{2}{T_s} \frac{z - 1}{z + 1} \quad p = j\omega_a \rightarrow z = \frac{1 + j\frac{\omega_a T_s}{2}}{1 - j\frac{\omega_a T_s}{2}} = e^{j2\pi f_d T_s}$$

Transform of the frequency axis between the prototype f_a and the discrete filter f_d :

$$\omega_a = \frac{2}{T_s} \tan(\pi f_d T_s)$$

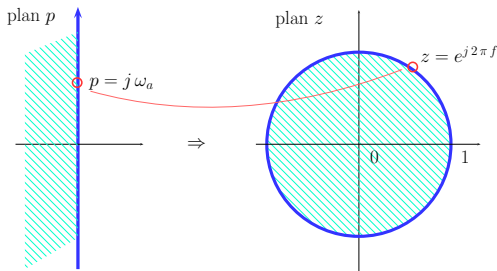

Advantages:

- ▶ Robust to process variation because the cut-off frequencies are fixed by ratios of capacitors
- ▶ Can be reconfigured by adjusting the sampling frequency
- ▶ Can be easily adapted to implement any kind of filter (low pass, high pass ...)

Drawbacks:

- ▶ SC filters are discrete time and therefore can not be used to implement AAF.
- ▶ Not suited for very frequency application because f_s should be high compared with the useful frequency.

Cascaded filter

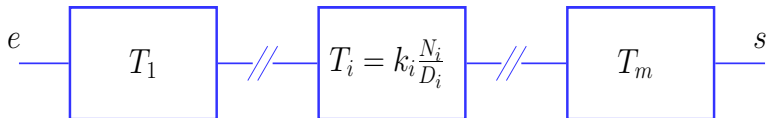

- ▶ A filtering function can be implemented as a cascade of several basic filters
- ▶ The cells should be designed in a way that connecting it to other cells should not change its transfer function
- ▶ The realization of the complete filter involves m intermediate functions :
 - ▶ Choice of the Denominators D_i
 - ▶ Choice of the numerators N_i
 - ▶ Gain allocation k_i

USB filter implementation

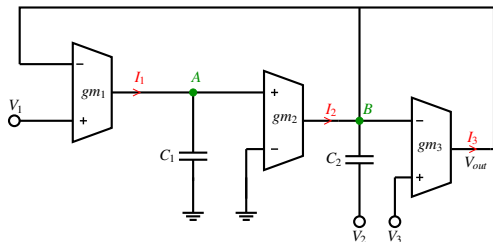

1. Determine the TF of the cell in the Laplace domain
2. Plot the Bode diagram of the modulus of the transfer function in the possible configurations
3. Express the TF for ($V_1(p) = 0$ and $V_2(p) = 0$) as follows:

$$H(p) = \frac{V_{out}(p)}{V_3(p)} = \frac{\frac{p}{Q \cdot \omega_0}}{\frac{p^2}{\omega_0^2} + \frac{p}{Q \cdot \omega_0} + 1}$$

Determine the expressions of ω_0 and Q .

4. By drawing the cell as a black box, propose an implementation.